

New Synthetic Applications of Oxycarbonylnitrenes

OTTO METH-COHN

National Chemical Research Laboratory, Council for Scientific and Industrial Research, Pretoria 0001, Republic of South Africa

Received February 3, 1986 (Revised Manuscript Received July 14, 1986)

The primordial formation of the molecules of life is believed to involve nitrene (NH) as a key nitrogenous building block.¹ A readily accessible derivative of nitrene is ethoxycarbonylnitrene.² Lwowski, in a 1970 review, concluded that "Applications of C-H insertion reactions of acyl nitrenes are severely limited" but did concede that intramolecular processes should be more practicable.³ It is the intention of this Account to restore alkoxycarbonylnitrenes to the primary synthetic role that their cousin, nitrene, occupied in the origin of the molecules of life.

The most thoroughly studied, most reactive and versatile of the whole family of nitrenes are the oxycarbonylnitrenes (or nitrenoformates) (1), much of the

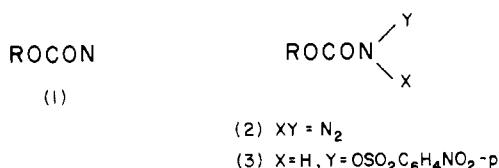

chemistry of which has been developed by Lwowski and his co-workers.² These nitrenes are most accessible in the singlet state (RN:, a highly reactive electrophile) by thermolysis of the corresponding azide (2) or through α -elimination following base treatment of the sulfonyloxyurethane (3), though this latter, low-temperature route is never as high yielding as the thermolytic approach. Photolysis of these azides is feasible but requires low-wavelength ultraviolet irradiation, which is frequently counter-productive and gives a mixture of singlet and triplet species (2:1 at 38 °C).⁴ In this Account a new efficient photoroute to pure singlet nitrenes is disclosed. Triplet oxycarbonylnitrenes (RN:, geminal diradicals) can be obtained by sensitized photolyses but their chemistry is relatively unexplored.

The remarkable electrophilic reactivity and specificity of nitrenoformates is illustrated in Scheme I, the reactions occurring in high yields from readily accessible azides.² Despite these unique reaction modes, the application of azidoformates in synthesis has been minimal. Thus, cyclization reactions of such nitrenes, apart from a few examples, is virtually unexplored.

Methods for Thermolysis and Pyrolysis of Azidoformates

One of the drawbacks of such a highly reactive species as a nitrenoformate is that few solvents are inert to its ravages. (In this Account thermolysis refers to solution reactions while pyrolysis implies gas-phase reactions.)

Otto Meth-Cohn was born in 1935 in The Hague, The Netherlands. All his training in chemistry was received at the University of Salford, England, apart from a postdoctoral spell with Salo Gronowitz in Norway and Sweden. After 22 years in the chemistry department at Salford, he took up his present appointment as Head of Organic Chemistry at the National Chemical Research Laboratory in 1983. His major current research interests, apart from nitrene chemistry, include synthetic methodology, asymmetric and stereo-controlled epoxidations and cycloadditions, the synthesis of useful but rare natural products, and novel heterocycles.

Scheme I.
Some Nitrene Pathways

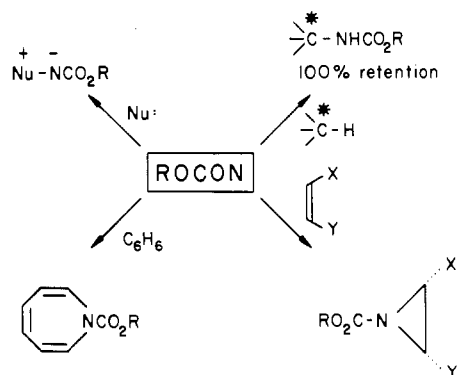

However, two simple solutions are available to the chemist:

Solution Thermolyses. Nitrenes tend to be unreactive towards halocarbons. An sp³ carbon bearing at least two geminal chlorines is inert to nitrene attack. Thus dichloromethane or chloroform are ideal solvents. However, azidoformates require temperatures of about 130 °C for smooth decomposition, and such solvents would require reaction under pressure. A teflon-lined autoclave is ideal for this purpose. We use a 250-mL Berghof Autoclave from Berghof, Harretstrasse 1, 7412 Eningen u.A., West Germany. Another solution is to employ 1,1,2,2-tetrachloroethane as the solvent (bp 146 °C).

Vapor-Phase Pyrolyses. Another problem encountered in nitrene chemistry is the well-known tendency for hot azides to explode. This has resulted in an understandable reluctance to vaporize all but the simplest azides. As a result, this ideal mode of encouraging unimolecular cyclizations of nitrenoformates has been largely overlooked. We have developed a simple, safe method whereby the azide is sprayed into the heated pyrolysis tube at ambient temperature with a stream of nitrogen.⁵ Most azidoformates, being esters, are conveniently liquids or low-melting solids (which can be maintained molten with a hair dryer or a jacketed inlet). Using this spray-pyrolysis technique (Figure 1) working at 1-2 mm pressure and usually at about 300 °C, we have successfully (and safely) pyrolyzed hundreds of azides in multigram amounts; high

(1) (a) Sato, S.; Kitamura, T.; Tsunashima, S. *Chem. Lett.* 1980, 687. (b) Hamada, J.; Shunashima, S.; Sato, S. *Bull. Chem. Soc. Jpn.* 1982, 55, 1739.

(2) For reviews, see: (a) Lwowski, W. "Carbonylnitrenes" *Nitrenes*; Lwowski, W., Ed.; Interscience: New York, 1970; p 18. Edwards, O. E. "Acyl nitrenes" *Nitrenes*; Lwowski, W., Ed.; Interscience: New York, 1970; p 225. (b) Lwowski, W. "Acyl azides and Nitrenes" *Azides and Nitrenes, Reactivity and Utility*; Scriven, E. F. V., Ed.; Academic: Orlando, FL, 1984; p 205.

(3) Reference 2(b), p 231.

(4) McConaghy, J. S.; Lwowski, W. *J. Am. Chem. Soc.* 1967, 89, 2357 and 4450.

(5) Clancy, M.; Hawkins, D. G.; Hesabi, M. M.; Meth-Cohn, O.; Rhouati, S. *J. Chem. Res. aMiniprint* 1982, 5, 78.

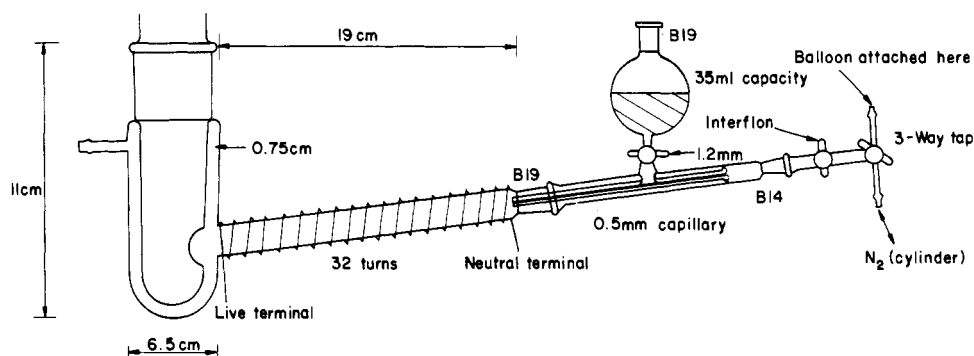

Figure 1. Spray pyrolysis equipment.

yields of products are normally obtained. A larger preparative version employs two pyrolysis tubes in tandem with condensation at the same cold finger. The apparatus is easily constructed and the furnace tube heating wire requires only 30 min work using flat Nichrome wire, fixed in place with blobs of car exhaust cement.

CH-Insertion of Nitrenoformates

Cyclohexyl Azidoformates. Alkyl⁶ and cycloalkyl azidoformates on thermolysis or pyrolysis readily yield the five-membered oxazolidinones and to a lesser degree, the six-membered oxazinones by intramolecular insertion with retention of stereochemistry. Yields of products seem to improve using our spray pyrolysis technique (Scheme II).

We have investigated intramolecular insertions of cyclohexyl nitrenoformates under various conditions (Scheme III) to clarify the stereo- and regioselectivity and temperature dependence of nitrene insertions.⁷ Several interesting features emerge: (i) The ratio of *cis*-**(5)** to *trans*-oxazolidinones (**(6)**) are purely a function of temperature rather than mode of generation of the nitrene. Indeed, if one calculates the equilibrium constant at our reaction temperatures of equatorial to axial conformers in cyclohexyl acetate as a close model of the azide (**(4)**),⁸ the ratios show remarkably close resemblance to our product ratios (Scheme III). This reveals the indiscriminate early-collision reactivity of the singlet nitrene, the product ratio reflecting solely the conformational equilibrium of the nitrene prior to reaction. Clearly, the axial azidoformate can only insert into the neighboring equatorial CHs (yielding the *cis* product **(5)**) while the equatorial conformer can yield both *cis* and *trans* products. These results are in contrast to the known equatorial preference of ethoxycarbonylnitrene.⁹ (ii) Since the oxazolidinones are readily cleaved in high yield (~80%) to give 2-aminocyclohexanols (KOH in triethylene glycol, N₂, 160 °C, 5 min) this method is also synthetically useful. (iii) In line with observations using acyclic azidoformates (Scheme II) no six-membered insertion products (only accessible from the axial conformer) were noted.

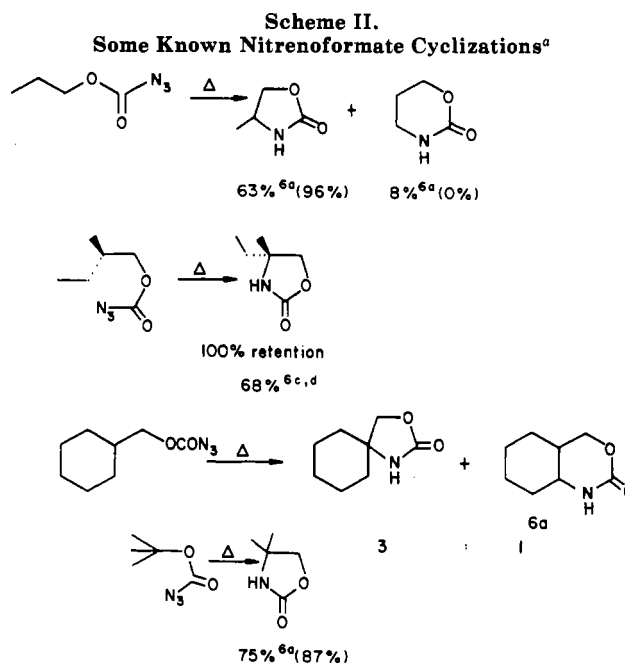

^a Yields in parentheses are from spray pyrolysis.

Examination of the conformationally rigid 4-*tert*-butylcyclohexyl azidoformates (**(7)** and **(10)**) reveals further surprises (Schemes IV and V). At lower temperatures a small equatorial preference in insertions of the *trans* isomer (**(7)**) may be expected based on Shingaki's results referred to earlier,⁹ but at higher temperatures there should be a trend towards equivalence in products. Our observed ratio at 140 °C of 1.4:1 preference for equatorial insertions is close to that of Shingaki (1.3:1). Surprisingly, a reproducible small preference for axial insertion is observed at 300 °C. This is not due to product instability or involvement of, e.g., a twist-boat conformation (about 0.5% contribution should be expected at 300 °C).

The *cis*-4-*tert*-butylcyclohexyl azidoformate (**(10)**) bears solely an axial azidoformate moiety, allowing attack at the neighboring equatorial CH and the 3- or 5-axial CH, leading to an oxazolidinone (**(11)**) or an oxazinone (**(12)**), respectively. Elevation of temperature merely reduces the selectivity for five-membered ring formation.

Finally, in order to underline the preference for tertiary > secondary > primary CH insertion of nitrenes in cyclic systems we have also examined the decomposition of both *cis*- and *trans*-2-methylcyclohexyl azidoformate (**(13)** and **(14)**) (Schemes VI and VII). In intermolecular acyclic thermolyses a typical situation is revealed by the ratio t:s:p = 32:10:1 with ethyl azido-

(6) (a) Kreher, R.; Kuhling, D. *Angew. Chem., Int. Ed. Engl.* **1965**, *4*, 69. See also: (b) Alewood, P. F.; Benn, M.; Reinfred, R. *Can. J. Chem.* **1984**, *52*, 4083. (c) Pyrolysis: Smolinsky, G.; Fenner, B. I. *J. Am. Chem. Soc.* **1964**, *86*, 3085. (d) Thermolysis: Yamada, S. I.; Ershima, S. T.; Achiwa, K. *Chem. Pharm. Bull.* **1965**, *13*, 751. (e) Wright, J. J.; Morton, J. B. *J. Chem. Soc., Chem. Commun.* **1976**, 668.

(7) Marais, P.; Meth-Cohn, O. *J. Chem. Soc., Perkin Trans. 1*, in press.

(8) This data was taken from: Dale, J. *Stereochemistry and Conformational Analysis*; Verlag Chemie: New York, 1978; p 154.

(9) Shingaki, T.; Inagaki, M.; Torimoto, N.; Takebayashi, M. *Chem. Lett.* **1972**, 1181.

Scheme III.
Product Variation of Cyclohexyl Azidoformate with Temperature

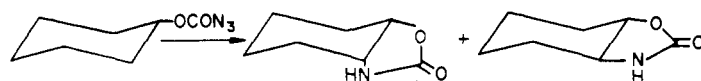

(4) Conditions	(5) Yield (%)	(6) Yield (%)	5 : 6	
			Obs.	Calc.
Δ , CH_2Cl_2 , 140°	30	29	1.0 ^{6a}	1.5
$h\nu$, CH_2Cl_2	31	25	1.2 ^{6a}	
$h\nu^*$, CH_2Cl_2 , 10°	38.5	35.5	1.1	1.1
Δ , $\text{Cl}_2\text{CHCHCl}_2$, 145°	44	32	1.4	1.5
Δ , pyrolysis, 250°	40	18	2.2	2.2
Δ , pyrolysis, 300°	51	22	2.3	2.2
Δ , pyrolysis, 500°	37	15	2.5	2.4

* Photolysis of TCT S,N-ylide (see Section 5a)

Scheme IV.
Products from *trans*-4-*tert*-Butylcyclohexyl Azidoformate: A Test of Equatorial vs. Axial Insertion

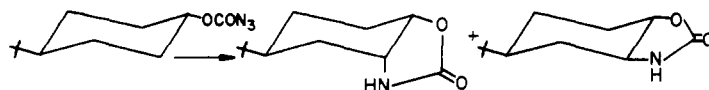

(7) Conditions	(8) Yield (%)	(9) Yield (%)	8 : 9	
			Obs.	Calc.
Δ , $\text{Cl}_2\text{CHCHCl}_2$, 140°	25	37	0.7	0.7
Δ , pyrolysis, 300°	31	28	1.1	0.7

Scheme V.
Products from *cis*-4-*tert*-Butylcyclohexyl Azidoformate: Five- vs. Six-Membered Insertion

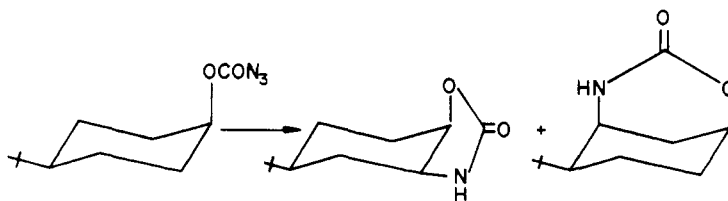

(10) Conditions	(11) Yield (%)	(12) Yield (%)	11 : 12	
			Obs.	Calc.
Δ , $\text{Cl}_2\text{CHCHCl}_2$, 136°	49	12	4.1	
Δ , pyrolysis, 300°	45	17	2.6	

Scheme VI.
Insertions of *trans*-2-Methylcyclohexyl Azidoformate: *t*:*s*:*p* Product Ratios

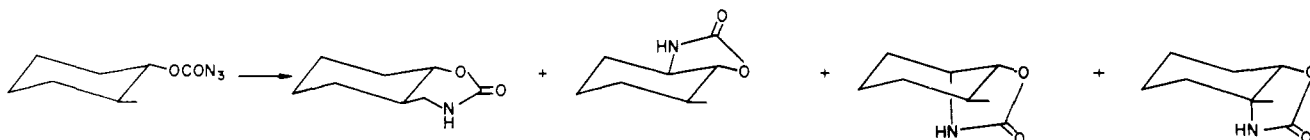

(13) Conditions	Yields (%)			
	1	2	3	4
$h\nu^*$, CH_2Cl_2 , 10°	4	18	6	34
Δ , CH_2Cl_2 , 150°	7	22	10	44

Scheme VII.
Insertions of *cis*-2-Methylcyclohexyl Azidoformate: t:s:p Product Ratios

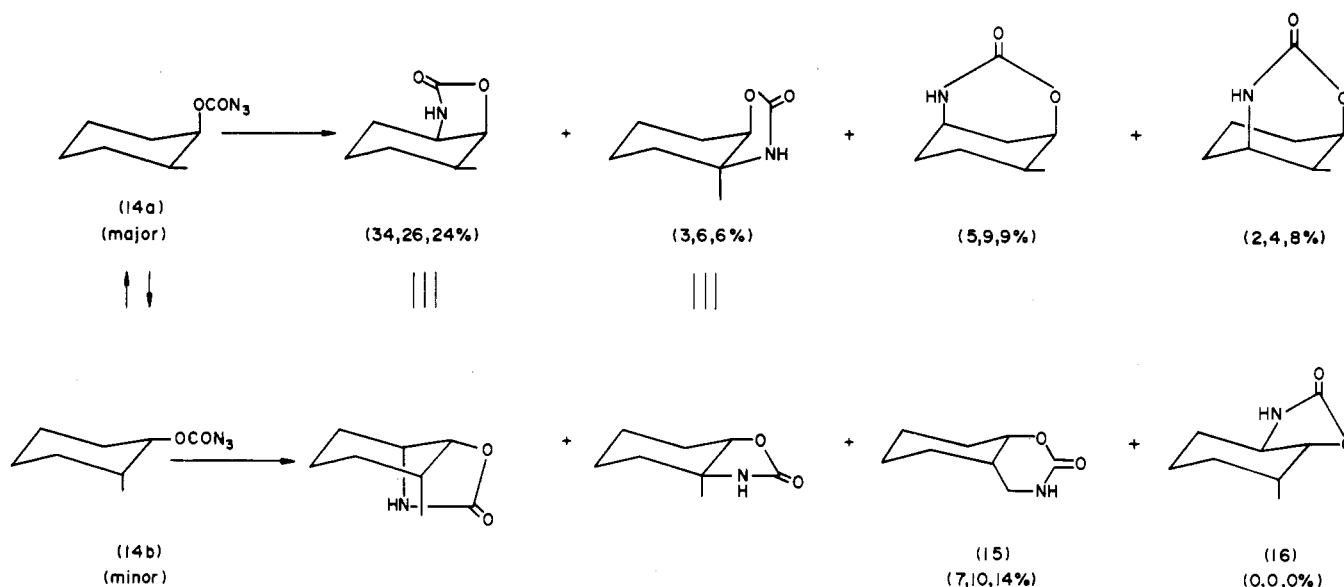

The three yields refer respectively to i) photolysis of the TCT-ylide in CH_2Cl_2 at 10°
 ii) thermolysis in CH_2Cl_2 at 150°
 iii) pyrolysis at 300°

formate and 2-methylbutane.¹⁰ In these intramolecular cases, because of the uncertain geometric variables present, statistical corrections are of dubious value. However, it is immediately evident that an evening-up of the insertion ratios occurs, reflecting the extra steric interactions in intramolecular-insertion transition states. Once again, however, low temperatures favored five- over six-membered products and revealed greater selectivity in t:s:p ratios.

Clearly, the major importance of factors determining transition-state conformations of the nitrenes are again vital in determining reactivity patterns. Thus with the *trans*-2-methylcyclohexyl azidoformate (13') interac-

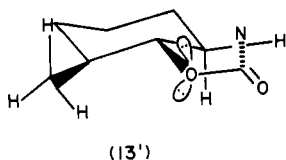

tions of the ether oxygen lone-pair orbitals with the adjacent methyl groups will limit the extent of secondary insertions relative to primary and tertiary attack. Furthermore, similar interactions increase the equatorial to axial insertion ratio from the normal 1.4:1 preference to 2.9:1 at 10°C and, an expectedly lower 2.25:1 at 150°C . These effects are evident in the product ratios in Scheme VI.

Since the *cis*-2-methylcyclohexyl azidoformate (14) is more conformationally mobile (the ratio of axial to equatorial azidoformate at 10°C should be $\sim 80:20$; at 150°C , $\sim 77:23$; and at 300°C , $\sim 71:29$), one would expect products from both conformers to be evident (Scheme VII) and their ratios to be determined largely by conformational and steric factors. Several facts deserve comment: (i) The minor conformer (14b) is the only source of the methyl insertion product (i.e., 15),

and as such this product accounts for approximately one-third of this reaction pathway at 10°C and half at 300°C . Surprisingly, no doubt because of lone-pair repulsion effects again, no secondary equatorial insertion product (16) was detected. (ii) The major product derives from *cis* insertion giving a five-membered ring from both nitrene conformers (14a and 14b). Furthermore, this reaction demonstrated how readily one can control conditions in a nitrene mediated reaction to optimize one pathway since operation at the lowest convenient temperature clearly favors (a) the axial azidoformate conformer, (b) the formation of five- over six-membered rings, and (c) secondary over primary insertion.

The importance of conformational and steric factors in determining the cyclization course of steroidal azidoformates has been noted by earlier workers.¹¹ Thus, the lanostanyl azidoformate (17) gave a remarkably high

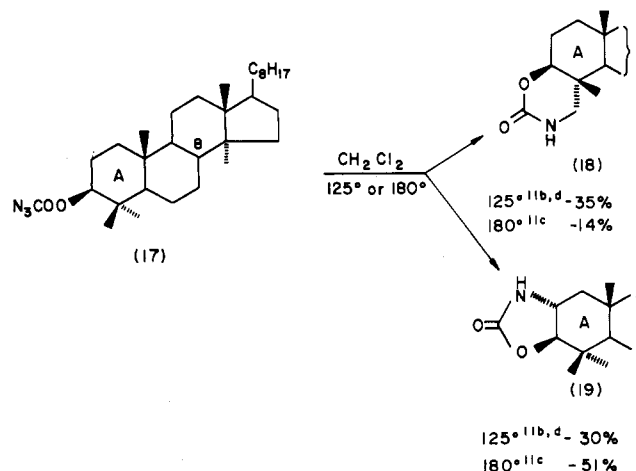

(11) Lanostanyl oxycarbonylnitrene insertions: (a) Edwards, O. E.; Paryzek, Z. *Can. J. Chem.* 1973, 51, 3866. (b) Jones, A. J.; Alewood, P. F.; Benn, M.; Wang, J. *Tetrahedron Lett.* 1967, 1655. (c) Czarny, M. R.; Benson, B. W.; Spencer, T. A. *J. Org. Chem.* 1977, 42, 556. (d) Alewood, P. F.; Benn, M.; Wang, J.; Jones, A. J. *Can. J. Chem.* 1977, 55, 2510.

(10) Breslow, D. S.; Prosser, T. J.; Marcantonio, A. F. *J. Am. Chem. Soc.* 1967, 89, 2384.

Scheme VIII.
Functionalization of Estradiol Using an Azidoformate

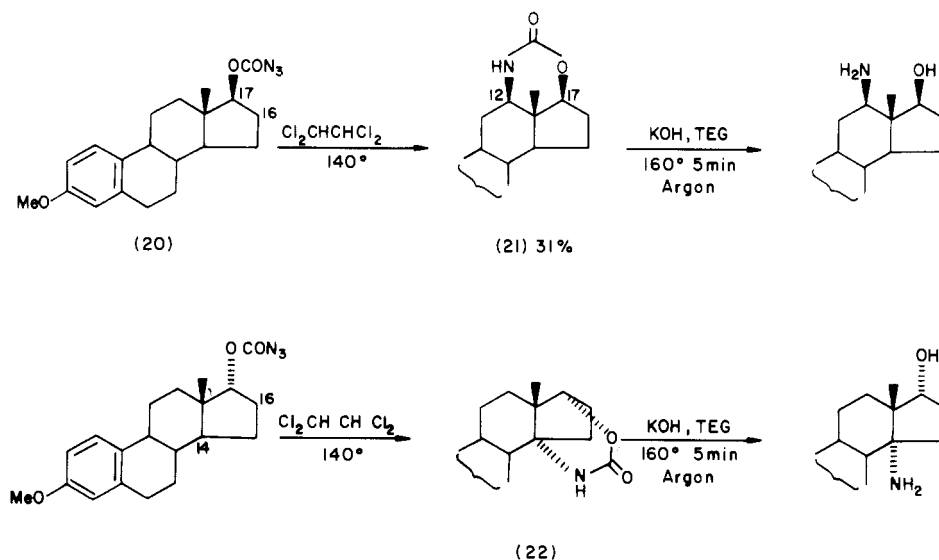

yield of the primary insertion product (18) at 125 °C relative to the secondary isomer (19), clearly understandable by the unfavorable steric interactions of the *gem*-dimethyl group on the transition state leading to the latter compound.^{11b,d} Although Spencer and co-workers^{11c} were unable to explain the diminution of primary insertion to give (18) when the thermolysis was conducted at 180 °C, it is quite clear from our data. Furthermore, we would predict that to increase this ratio still further in favor of 18, photolysis of the nitrene precursor at 10 °C or less would be effective.

In summary, the factors responsible for the relative lack of selectivity inherent in nitrene insertions should be in measure controllable, steerable, and predictable. By recognizing that it is principally the conformer populations of the azide prior to decomposition that determines insertion products, nitrenes have indeed a synthetically valuable role, despite Lwowski's gloomy prediction.³

Steroidal Azidoformates. With these data in mind we have begun to explore the applications of nitrene insertions in steroid functionalization.⁷ Some work on lanostanyl azidoformates has already been commented on.¹¹ The apparent limited regiocontrol of the reactions is offset by the potential for functionalizing unactivated sites in a stereospecific manner. Furthermore, since we have discovered conditions for the ready hydrolysis of such products to give useful amino alcohols, considerable synthetic benefits accrue. Some examples are revealed in Scheme VIII based on estradiol azidoformates. The 17 β -azidoformate (20) usefully functionalizes the 12 β -site (21) while the corresponding 17 α -derivative yields the 14 α -functionalized steroid (22), in both cases the products being admixed with the easily separated 16-substituted isomer (43% in each case). Work is in hand to block the undesired 16-substitution.

Using the hydrolyzing conditions referred to above, we have generated the corresponding 12 β -amino- and 14 α -aminoestradiols in high yield. Since amines can be readily transformed into most other functional groups by classical means or Katritzky's pyrylium salt methodology,¹² these derivatives have considerable synthetic

potential.

We next turned our attention to remote functionalization of steroids via nitrenes following Breslow's fascinating biomimetic methodology.¹³ Breslow has reported briefly on abortive attempts to utilize the extremely potent phosphoryl nitrenes in such applications.¹⁴ We argued that, given a nitrene-resistant long arm on which to hang the azidoformate and knowing that singlet nitrenes have extremely short lifetimes, it was probable that this collision would be with a solvent molecule leading to intersystem crossing. In other words, we would expect the triplet nitrene to be the functionalizing species. From the little that is known about triplet oxycarbonylnitrenes one would expect hydrogen abstraction rather than insertion to occur, much as in Breslow's various photogenerated radical approaches.¹³ However, the known ability of triplet nitrenes to perform double abstractions may throw an interesting variation into this approach.

With regard to the inert but cleavable long arm we selected the easily synthesized groups $\text{OCO}(\text{CH}_2)_n\text{OCON}_3$ to attach to the 17-position of the steroid framework. With $n = 1$ the arm clearly was too short and restricted for intramolecular attack, and solely the corresponding carbamate resulted (St- $\text{OCOCH}_2\text{OCONH}_2$; St = steroid) from both the 17 α - and 17 β -derivative, indicative of triplet intermolecular abstraction. However, with the next higher homologue, we observed intramolecular reaction. From examining Dreiding models, we envisaged that the 17 α -azidoformate (22), would give access to many of the α -face hydrogens especially those in the B-ring. CH-9 is particularly attractive being tertiary and benzylic. In the event three products were isolated, indicative of intramolecular attack, probably initiated by initial H-9 abstraction and subsequent elaboration (Scheme IX).

(12) (a) Katritzky, A. R. *Tetrahedron* 1980, 36, 679. (b) Katritzky, A. R.; Marson, C. M. *Angew. Chem., Int. Ed. Engl.* 1984, 23, 420.

(13) (a) Breslow, R. *Chem. Soc. Rev.* 1972, 1, 553; (b) *Acc. Chem. Res.* 1980, 13, 170.

(14) Breslow, R.; Feiring, A.; Herman, F. *J. Am. Chem. Soc.* 1974, 96, 5937. Breslow, R.; Herman, F.; Schwabacher, A. W. *J. Am. Chem. Soc.* 1984, 106, 5359.

Scheme IX.
Remote Functionalization of Estradiol Using an Azidoformate

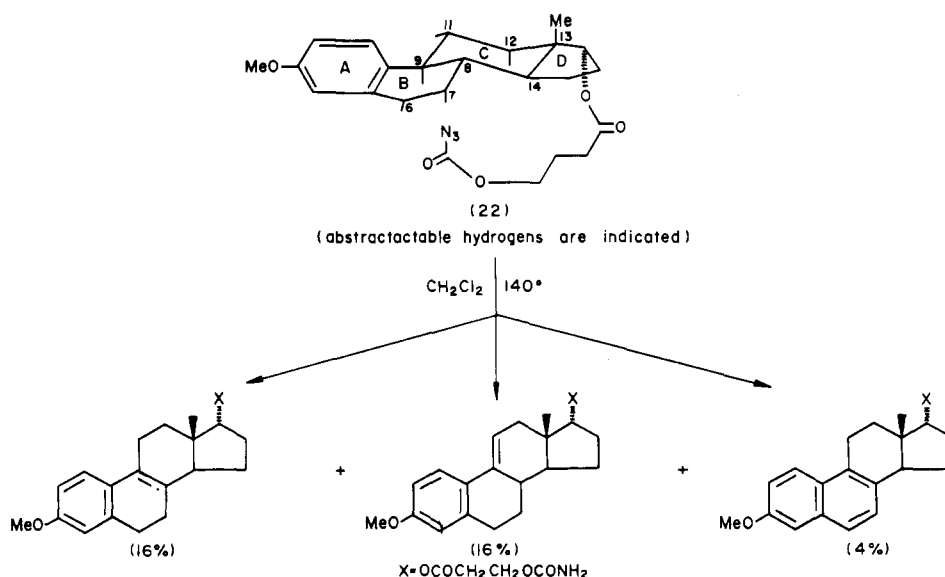

Scheme X.
Azepine Formation from Benzenes

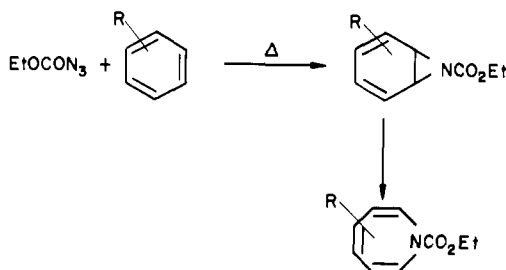

The remote functionalization of steroids using nitrenes is under active scrutiny.

Intramolecular Attack of Nitrenes on Benzenes

Phenyl Azidoformates. Ethoxycarbonylnitrene has long been known to add avidly to benzenes,² the product benzaziridine undergoing electrophilic expansion to yield an azepine (Scheme X). Phenyl azidoformates on the other hand are readily thermally cyclized to yield benzoxazolones by way of an electrophilic substitution mechanism (Scheme XI), the reaction being especially suited to spray pyrolysis conditions.¹⁵ Since the benzoxazolones are readily hydrolyzed to *o*-aminophenols (KOH, triethylene glycol, 160 °C, N₂, 5 min) in high yields, this constitutes an efficient route to such systems.

However, 2,6-disubstituted phenyl azidoformates follow quite a different course (Scheme XII).¹⁵ With the 2,6-dimethyl derivative (23, R = Me) the initially formed isocyanatocyclohexadienone rapidly undergoes a known type of Diels-Alder dimerization to give a stable crystalline adduct (24) capable of thermal re-

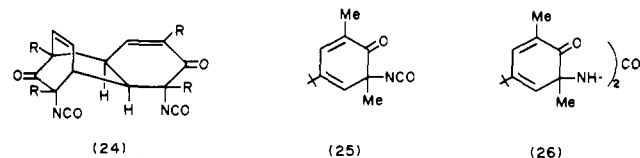

(15) (a) Meth-Cohn, *O. Heterocycles* 1980, 14, 1497. (b) Meth-Cohn, O.; Rhouati, *S. J. Chem. Soc., Chem. Commun.* 1981, 241.

Scheme XI.
Ortho Functionalization of Benzenes via Nitrenes

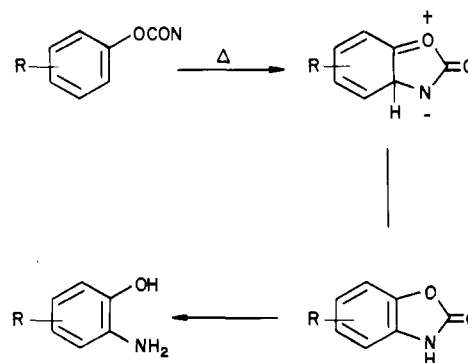

R = H, Me, Cl, Ph

Scheme XII.
Cyclohexadienyl Isocyanates from 2,6-Disubstituted Phenyl Azidoformate

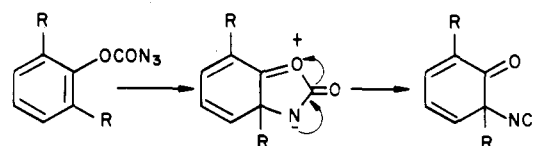

versal. The corresponding 4-*tert*-butyl-2,6-dimethylphenyl azidoformate gives a stable monomer (25). These dienones undergo the usual isocyanate reactions giving carbamates with alcohols, ureas with amines, amides with Grignard or organolithium reagents, and ureas (e.g., 26) on chromatography, without interference of the dienone function. Conversely, cycloadditions with dienophiles (e.g. maleic anhydride, benzoquinone, and dimethyl acetylenedicarboxylate) are readily conducted across the diene unit. The prospects for cyclizations remain to be exploited. When the isocyanate (24, R = Me) was heated in *o*-dichlorobenzene solution for 16 h, 4,7-dimethylbenzoxazolone was obtained by the 1,2-shift of a methyl group.

2,6-Diisopropylphenyl azidoformate shows a fascinating additional feature on pyrolysis (Scheme XIII).¹⁶

Scheme XIII.
Temperature-Switchable Nitrene-Mediated Reactions

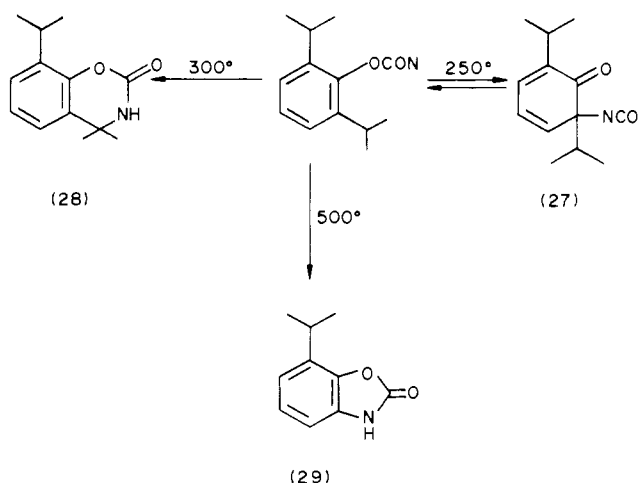

At 250 °C the isocyanate (27, as its dimer) is the major product while formation of the CH-insertion product (28) becomes the primary pathway at 300 °C. At 500 °C solely the benzoxazinone (29) is isolated, being a minor contaminant at lower temperatures. Furthermore, the dimer of the isocyanate (27) transforms efficiently into the other two products in refluxing trichlorobenzene, revealing the unique versatility of the nitrene-isocyanate duo. A non-nitrene mechanism for the conversion of the isocyanate (27) into the benzoxazolone (29) or the benzoxazinone (28) cannot be ruled out at this stage. A similar dichotomy is seen when the unsymmetrical 2,4-di-*tert*-butyl-6-methylphenyl azidoformate is pyrolyzed giving solely a cyclohexadienone at 240 °C, but at higher temperature the thermodynamically preferred product (31) of attack at

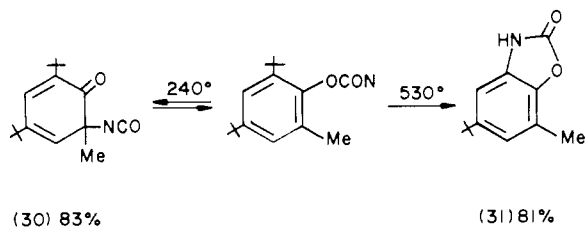

the more hindered site is only obtained.¹⁶ Again, the isocyanate (30) yields the benzoxazolone (31) on heating.

Not surprisingly, 2,6-dichlorophenyl azidoformate gave 4,7-dichlorobenzoxazolone on pyrolysis, by a 1,2-shift of a chlorine in the intermediate (23, R = Cl). However, 2-methyl-6-phenylphenyl azidoformate (32)

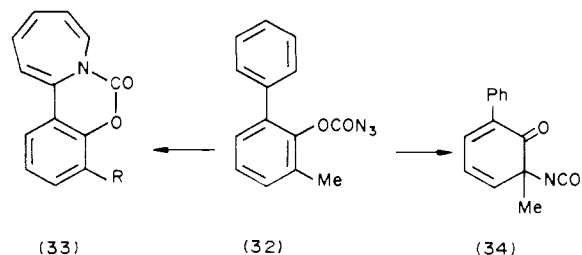

revealed a new facet of nitrene reactivity in that while the isocyanate (34) again was isolated as its dimer, ad-

(16) Hawkins, D. G.; Meth-Cohn, O.; Rhouati, S. *J. Chem. Soc., Chem. Commun.* 1983, 1254.

Scheme XIV.
An Easy Route to 4-Azaazulene

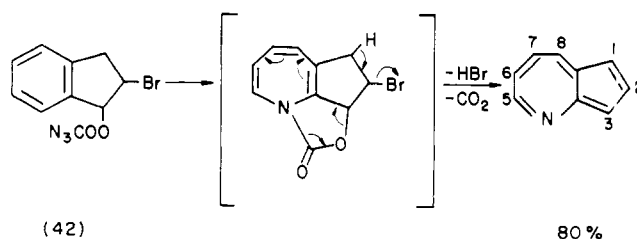

dition to the pendant phenyl group to give an azepine (33, R = Me) was the preferred course (1:3).¹⁶ The analogue (33, R = H) was also preferred (2:1) over benzoxazolone formation when 2-phenylphenyl azidoformate was pyrolyzed.

Benzyl Azidoformates. As shown in the last scheme (32 \rightarrow 35), a suitably situated nitrene can *add* intramolecularly to benzenes. Benzyl azidoformates (35) proved ideal candidates for this transformation

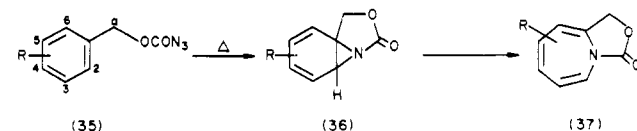

giving high yields of products.¹⁷ However, the initially formed azepines (37) being constrained by the fused five-membered ring into a more planar conformation, underwent a variety of subsequent transmigrations in order to escape their antiaromatic instability. Generally, multisubstitution, especially in the 2,6-positions of the azide allowed isolation of metastable azepines (37, e.g., 4,8-Cl₂, 4,8-Me₂, 4,6,8-Me₃, 4,5,7,8-Me₄, 3-*tert*-butyl, or 6-*tert*-butyl). X-ray crystallography was achieved with the orange 4,8-dichloroazepine (37, R = 4,8-Cl₂), and the data, together with ultraviolet, ¹H NMR and ¹³C NMR data were compared with published material for azepines and especially with that of the higher analogue (45) bearing a six-membered ring.¹⁸ Taken together the clearly greater planarity of the present system (37) was evident. This fact was revealed chemically by the variety of pathways followed for stabilization. Paquette and his co-workers¹⁹ noted that *N*-acylazepines underwent thermal [6 + 4] dimerizations at 130 °C, and at 200 °C they yield [6 + 6] dimers. The majority of the azepines (37) indeed yielded [6 + 4] dimers either instantly on formation or on standing. *Syn*- (38), *anti*- (39), or a mixture of both dimers were formed.^{17a}

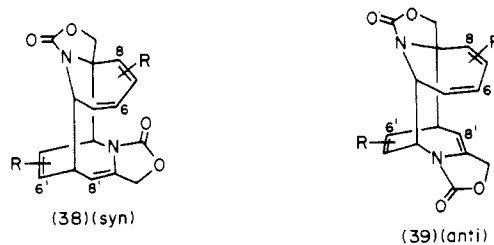

However, 5,7-dimethyl- or 5,7-dichloroazepines (37) slowly transformed into [6 + 6] dimers, presumably

(17) (a) Meth-Cohn, O.; Rhouati, S. *J. Chem. Soc., Chem. Commun.* 1980, 1161. (b) meth-Cohn, O.; Patel, D.; Rhouati, S. *Tetrahedron Lett.* 1982, 5085.

(18) Dillen, J. L. M.; Meth-Cohn, O. *S. Afr. J. Chem.* 1984, 37, 171.

(19) Paquette, L. A.; Barrett, J. H.; Kuhla, D. G. *J. Am. Chem. Soc.* 1969, 91, 3616.

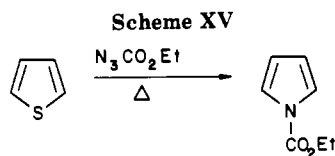

because of unfavorable substitution for [6 + 4] reaction.^{17b} Furthermore, the 4,6,8-trimethyl- and 4,5,7,8-tetramethylazepines (37) surprisingly lost formaldehyde to give mesityl and duryl isocyanates (40) on stand-

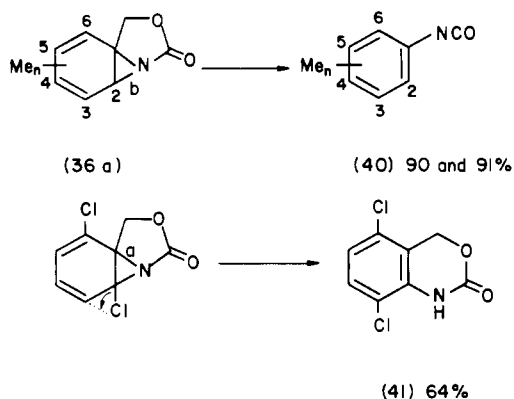

ing.^{17b} This sequence is best viewed as an electrocyclic breakage of bond *b* of the aziridine valence-tautomer (36a) of the azepine (37). If one views this process to have a polar transition state with a negatively polarised nitrogen then the 2,4- and 6-methyl groups of the intermediate (36) stabilize the positive charge mesomerically, favoring such a pathway. By contrast, when the 4,5-dichloroazepine (37, R = 4,7-Cl₂) was heated at 130 °C for 4 h, breakage of bond *a* of the putative aziridine with a 1,2-chlorine shift gave a 5,8-dichlorobenzoxazinone (41).^{17b}

This intramolecular azepine formation has been put to very effective use in a one-pot high-yield synthesis of the unknown 4-azaazulene (Scheme XIV).²⁰ The indene-derived azidoformate (42) is best spray-pyrolyzed through a hot tube packed with a mixture of copper turnings and calcium oxide, whereby elimination of hydrogen bromide and carbon dioxide liberates the deep-blue azaazulene. Despite its instability in air, several grams were prepared and the system was fully explored chemically and physically. Also several derivatives were similarly made this way including the 5-bromo and 6-methoxy analogues. As with its isomer, quinoline, 4-azaazulene underwent electrophilic substitution at the non-hetero-ring peri positions, formed an *N*-oxide, and underwent cycloadditions with dimethyl acetylenedicarboxylate initiated by attack at nitrogen. Like azulene,²¹ on the other hand, it added tetrachlorothiophene dioxide with SO₂ extrusion to give the benzazaazulene (43) in low yield.²²

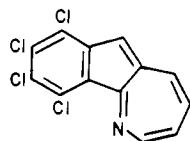

(43)

(20) (a) Meth-Cohn, O.; Moore, C. *J. Chem. Soc., Chem. Commun.* 1983, 1246; (b) *J. Chem. Soc., Perkin Trans. 1* 1985, 1793.

(21) Gupta, Y. N.; Houk, K. N. *Tetrahedron Lett.* 1985, 2607.

Finally, it is not surprising that 2-phenethyl azidoformates (44) yielded a mixture of the stable azepines (45) and the products of benzylic insertion (46), the

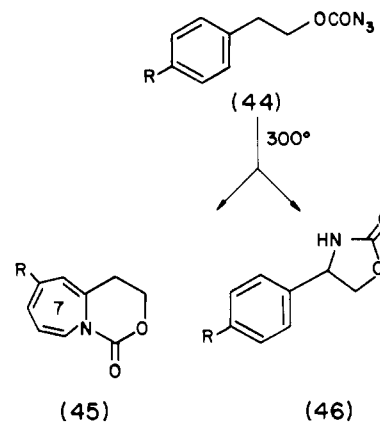

R	Yield (%)	
H	30	30
MeO	61	10
Bu [†]	56	12
Me	54	29
Cl	38	22

relative yields depending upon the nature of the substituent, R, while the next higher homologue, 3-phenylpropyl azidoformate gave solely side-chain inserted products (47, 31% and 48, 17%).^{17b} This result

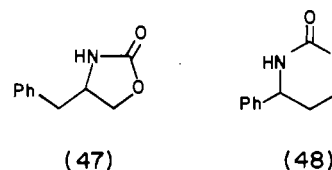

reveals the reverse of normal ring-size preference, the driving force being benzylic insertion. By contrast, phenylpropylsulfonyl azide on pyrolysis yields only products of aromatic ring attack, showing the large difference in geometric and other factors involved in sulfonylnitrene chemistry.^{23a} 2,6-Dichloro- or -dimethylphenethylsulfonyl azides, the analogues of our benzyl azidoformates did not yield azepines but rather 2,1-benzothiazine 2,2-dioxides, the analogues of 41, by 1,2-shift of a substituent.^{23b} 2,5-Bis(trifluoromethyl)phenylsulfonyl azide does, however, yield an azepine on thermolysis.²³

Attack of Nucleophiles by Nitrenes: Formation of Thiophene *S,N*-Ylides and Their Synthetic Utility

The formation of *N*-pyridinium ylides by the thermolysis of ethyl azidoformate in pyridine is well known.²⁴ The same azide is reported to attack carbon

(22) Meth-Cohn, O.; Moore, C., unpublished work.

(23) (a) Abramovitch, R. A.; Kress, A. O.; McManus, S. P.; Smith, M. R. *J. Org. Chem.* 1984, 49, 3114, and references therein. (b) Abramovitch, R. A.; Kress, A. O.; Pillay, K. S.; Thompson, W. M. *J. Org. Chem.* 1985, 50, 2066.

Scheme XVI.
Tetrachlorothiophene *S,S*-Dioxide: A Valuable and Reactive Diene

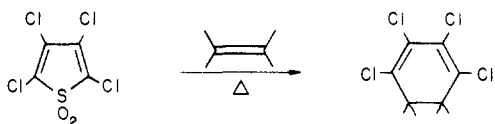

rather than sulfur when thiophene replaces pyridine, giving ultimately a pyrrole (Scheme XV).²⁵ Knowing that nitrenes are strongly halophobic, we examined the action of ethoxycarbonylnitrene on tetrachlorothiophene (TCT) and were gratified to isolate the *S,N*-ylide (49), a stable crystalline solid in fair yield.²⁶ This new class of *S*-substituted thiophenes (3-oxides, *S,C*-ylides, and *S*-alkyl salts are known²⁷) was expanded to the methyl- and phenyloxycarbonyl homologues as well as the *S*-toluenesulfonamido analogue by thermolyzing the appropriate azide in tetrachlorothiophene. However, the reaction appears to be unique to tetrachlorothiophene in so far as isolation of stable ylides is concerned. This unprecedented uniqueness needs questioning and is addressed later. The ylides (49) are remarkably useful and novel intermediates.

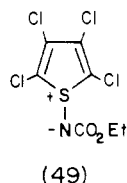

TCT *S,N*-Ylides as Ready Photo Sources of Pure Singlet Nitrenes. UV irradiation of the ylides (49) with a >290 nm source rapidly, cleanly, and efficiently yields pure singlet nitrenes.²⁶ This is in marked contrast with azide photolysis which requires low-wavelength light and invariably gives much triplet nitrene. It would appear that light absorption by the thiophene chromophore leads to S–N bond cleavage as a secondary step. Albeit the ylide (49) gives very high yields of insertion product on irradiation in cyclohexane (with no hydrogen abstraction product), the phenyloxycarbonyl ylide on photolysis in methylene chloride yields benzoxazolone in high yield and the toluenesulfonamido ylide also gives cyclohexane inserted material *without* contamination by *p*-toluenesulfonamide, an unprecedented observation.

The role of the ylides in intramolecular nitrene chemistry has been mentioned earlier (section 3). Their potential in photoaffinity labeling experiments is particularly exciting and under study. To date, all such studies have utilised aryl azides, which rarely undergo CH insertion chemistry.²⁸ Most biochemical systems could not tolerate the low wavelengths required for carbonyl azide photolyses. The ylides have one further virtue in that following the substrate labeling by CH

(24) (a) Streith, J.; Cassal, J. M. *Angew. Chem., Int. Ed. Engl.* **1968**, *7*, 129. (b) Abramovitch, R. A.; Takaya, T. *J. Org. Chem.* **1972**, *37*, 2022. (c) Kwart, H.; Benko, D. A.; Streith, J.; Harris, D. J.; Shappiser, J. L. *J. Am. Chem. Soc.* **1978**, *100*, 6501. (d) Harris, D. J.; Snieckus, V. *J. Chem. Soc., Chem. Commun.* **1976**, 845. (e) Tsuchiya, T.; Enkaku, M.; Kurita, J.; Sawanishi, H. *J. Chem. Soc., Chem. Commun.* **1979**, 534.

(25) Hafner, K.; Kaiser, W. *Tetrahedron Lett.* **1964**, 2185.

(26) Meth-Cohn, O.; van Vuuren, G. *J. Chem. Soc., Chem. Commun.* **1984**, 190; *J. Chem. Soc., Perkin Trans. 1* **1986**, 233.

(27) Gronowitz, S., Ed., *Thiophene and its Derivatives*; Wiley: New York, **1985**; Vol. 1, pp 571 and 629.

(28) See ref 2(b), p 433 for a recent review.

Scheme XVII.
An Efficient Source of Thionitroso Compounds

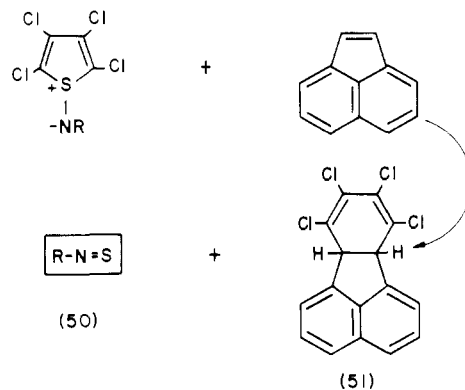

Scheme XVIII.
Methods for Trapping Transient Thionitroso Compounds

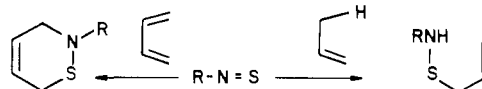

insertion, carbamate cleavage of the reagent is trivial, leaving a very bioacceptable, firmly attached, and easily identified amino group (e.g., as ¹⁵N).

TCT *S,N*-Ylides as Sources of Thionitroso Compounds.²⁹ Tetrachlorothiophene dioxide is well established as a powerful Diels–Alder diene, readily reacting with electron-rich and electron-poor dienophiles with concomitant extrusion of sulfur dioxide (Scheme XVI).³⁰ Spectroscopic and crystallographic data^{29,31} showed the *S,N*-ylides were considerably dienic rather than aromatic (as with the related *S,C*-ylides) revealing very short S–N bonds. As such, cycloadditions were conducted and these ylides shown also to be highly reactive to a wide range of nucleophilic alkenes. Acenaphthylene for example reacted quantitatively in the cold in 10 min to give the expected adduct (51) and, more interestingly the unknown series of acyl- and sulfonylthionitroso compounds (50, Scheme XVII). Very few thionitroso compounds are known, and only those where R is electron-releasing (NMe₂ or NPh₂) are isolable.³² The present series proved the most reactive and transient of the species. They were readily trapped with nucleophilic dienes as 1,2-thiazines and with alkenes as ene adducts (Scheme XVIII). Their amazing reactivity is underlined by the similar extent of diene and ene reactions undergone by isoprene and 2,3-dimethylbutadiene and (unlike isosteric acylnitroso compounds) by the regiospecificity of the ene reaction.²⁹

Do Thiophenes in General React with Nitrenes at Sulfur? The unique role of TCT has been referred to above. Despite examination of a wide range of other thiophenes,³³ no other analogues yield stable *S,N*-ylides. Even replacement of one chlorine (even in the β -position) by bromine, fluorine, hydrogen, or methyl groups inhibits ylide isolation. However, that does not answer the question; if the azide decompositions were conducted in the presence of a trap to capture a transient ylide, a clearer picture would emerge.

(29) Meth-Cohn, O.; van Vuuren, G. *J. Chem. Soc., Chem. Commun.* **1984**, 1144; *J. Chem. Soc., Perkin Trans. 1* **1986**, 245.

(30) Raasch, M. S. *J. Org. Chem.* **1980**, *45*, 856.

(31) Dillen, J. L. M.; Meth-Cohn, O., *S. Afr. J. Chem.*, in press.

(32) See ref 29 for full bibliography on RNS compounds.

(33) Meth-Cohn, O.; van Vuuren, G. *Tetrahedron Lett.* **1986**, 1105.

Chart I.
Ylide-Derived Products from the Reaction of Thiophene
and Ethyl Azidoformate

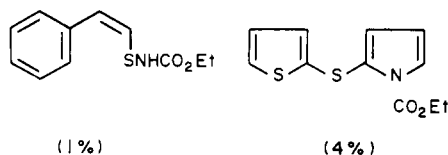

When ethyl azidoformate was thermolyzed in methylene chloride solution containing acenaphthylene and a variety of thiophenes, fluoranthenes or their dihydro-derivatives (51) were indeed isolated in yields from 3–26%. Thus thiophene, 2,5-dimethyl-, 2,5-dichloro-, 2,5-dimethoxy-, tetrabromo-, 2,5-dichloro-3,4-dibromothiophene all yielded ylide-derived fluoranthenes, the halo derivatives giving the dihydro compounds (51). Furthermore a more careful investigation of the original literature reaction²⁵ of thiophene with ethyl azidoformate without any trap revealed several fascinating (and unreported) products, clearly derived

by cycloadditions of an intermediate ylide (Chart I).³³ We leave the reader to enjoy solving the mechanistic perambulations involved.

We are of the opinion that hard electrophiles in general attack thiophenes at sulfur commonly. This contentious issue needs investigating.

Future Prospects

Oxycarbonylnitrenes clearly have a Herculean potential, almost untapped, in synthesis. This prospect is especially attractive and in need of exploitation in cyclizations. The biochemical applications referred to of photoaffinity labeling are especially exciting. Furthermore, by use of their remarkable energy, new, interesting, and useful intermediates typified by acyl- and sulfonylthionitroso compounds are rendered readily accessible. This almost virgin field awaits the entrepreneurial nitrene chemist.

I am deeply indebted to all my co-workers indicated in the references in this review, as well as to the Science Research Council, Great Britain, who funded much of the earlier work.

Organic Reactions in Sulfuric Acid: The Excess Acidity Method

ROBIN A. COX

Department of Chemistry, University of Toronto, Toronto, Ontario, Canada M5S 1A1

Received July 2, 1986 (Revised Manuscript Received September 26, 1986)

Large numbers of organic reactions take place in aqueous sulfuric and other strong acid media. A not particularly exhaustive list would include: hydrolyses, dehydrations, hydrations, isomerizations, electrophilic substitutions, aromatic rearrangements, carbonyl reactions, and a number of other reactions. Not surprisingly, much attention has been given to the elucidation of reaction mechanisms in acidic solutions.



$$pK_{BH^+} = \log I + pH \quad (2)$$

$$pK_{BH^+} = \log I - \log (a_{H^+}f_B/f_{BH^+}) = \log I + H_0 \quad (3)$$

For almost all of these reactions, protonation of the substrate is of critical importance. This can either be the rate-determining step (A-S_E2 mechanism), or a fast preequilibrium process, and the protonated substrate can then give product directly (A-1), or react with a nucleophile or base in the slow step (A-2). Taking as a model the protonation of a weak base B, reaction 1, in the dilute acid region¹ the acid dissociation constant of BH⁺ can be defined in terms of molar concentration C as $K_{BH^+} = C_B C_{H^+} / C_{BH^+}$, which, on taking logarithms and substituting the ionization ratio I for C_{BH^+} / C_B ,

becomes eq 2. In nonideal strong acids activities *a* and/or activity coefficients *f* must be used; $K_{BH^+} = a_B a_{H^+} / a_{BH^+} = (C_B / C_{BH^+}) a_{H^+} (f_B / f_{BH^+})$ and eq 2 becomes eq 3. An acidity function *h*₀ can be defined, following Hammett,² by $h_0 = a_{H^+} f_B / f_{BH^+}$, provided that B is a primary aromatic amine;^{3,4} $H_0 (= -\log h_0)$ in eq 3 is defined in the same way as pH in eq 2.³

H₀ and Reaction Rates

The A-1 mechanism is represented by reactions 4 and 5; fast preequilibrium protonation of the substrate S followed by rate-determining reaction of SH⁺, either to some intermediate A⁺ which subsequently reacts quickly, or to product directly. Reactions in sulfuric

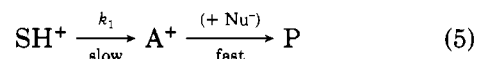

$$k_{\psi}(C_S + C_{SH^+}) = k_1 a_{SH^+} / f_{\psi} = k_1 C_{SH^+} (f_{SH^+} / f_{\psi}) \quad (6)$$

$$\log k_{\psi} - \log (C_S / (C_S + C_{SH^+})) = \log (k_1 / K_{SH^+}) - H_0 + \log (f_{BH^+} f_S / f_{\psi} f_{\psi}^*) \quad (7)$$

$$\log k_{\psi} - \log (C_{SH^+} / (C_S + C_{SH^+})) = \log k_1 + \log (f_{SH^+} / f_{\psi}^*) \quad (8)$$

(1) The standard state is a hypothetical acid solution of unit activity, as for pH measurements, and the reference state (unit activity coefficients) is infinite dilution in water.

(2) Hammett, L. P.; Deyrup, A. J. *J. Am. Chem. Soc.* **1932**, *54*, 2721.

(3) See the extensive discussion and listing of acidity functions in Cox, R. A.; Yates, K. *Can. J. Chem.* **1983**, *61*, 2225.

(4) Jorgenson, M. J.; Hartter, D. R. *J. Am. Chem. Soc.* **1963**, *85*, 878.

Robin A. Cox was born in England in 1943 and educated there, obtaining a B.Sc. from the University of Southampton in 1965. He then migrated to Canada, to McMaster University in Hamilton, Ontario, receiving a Ph.D. from that institution in 1970. Following postdoctoral work at Queen's University with Erwin Bunzel, and at the University of British Columbia with Ross Stewart, he took up his current position as Senior Tutor at the University of Toronto in 1975.